

**NOTICE INVITING TENDER FOR
SETTING-UP IT CELL IN THE LIBRARY BUILDING AT GROUND
FLOOR, OPPOSITE TO PROPOSED CLASS ROOMS, IN NIB NOIDA.**

Tender No. 08/2015-2016/Engg. (Civil)

SCHEDULE OF BIDS

1	Period of issue / download of Tender document	04.08.2016 to 18.08.2016
2	Last Date & time of submission of Tenders	19.08.2016 at 3:00 P.M
3	Pre Bid meeting	12.08.2016 at 3:00 P.M
4	Date & time of Opening of Technical Bids	19.08.2016 at 4:00 P.M
5	Opening of Price Bids	To be intimated separately only to the technically qualified bidders.
6	Tender Fee	Rs. 525/- (Rs. Five hundred twenty five) including 5% U.P. VAT, by demand draft in favour of "National Institute of Biologicals, Noida" payable at Noida.

Name of bidder	
Address of Bidder	
Phone Nos.	i- Landline Nos. ii- Cell Nos.
E-mail Id	
Contract Persons & their mobile nos.	i- ii- iii-

JULY – 2016



NATIONAL INSTITUTE OF BIOLOGICALS

(Ministry of Health & Family Welfare)

A-32, SECTOR- 62 (INSTITUTIONAL AREA),

NOIDA – 201 307 (U.P)

Tel: 0120-2400022, 2400072, Fax: 0120-2400074, 2403014

e-mail: info@nib.gov.in Website: www.nib.gov.in

National Institute of Biologicals (NIB)



NATIONAL INSTITUTE OF BIOLOGICALS
Plot No.A-32, Sector-62(Institutional Area), NOIDA-201 307(U.P)
Tel: 0120-2400022, 2400072, Fax: 0120-2400074, 2403014
E-mail: info@nib.gov.in Website: www.nib.gov.in

NOTICE INVITING TENDERS

Tender No. 08/2015-2016/Engg. (Civil)

Invitation to Tenders for “Setting-up IT Cell in the Library Building at Ground Floor, opposite to proposed Class Rooms” in NIB Noida.

Sealed tenders are invited from experienced civil work contractors on the attached tender form for **“Setting-up IT Cell in the Library Building at Ground Floor, opposite to proposed Class Rooms”** in NIB Noida. Bidders are advised to quote competitive rates for this work, on the enclosed tender format including all taxes, duties, labour, T & P etc. required for proper completion of the work. The tender form can be down loaded **04.08.2016 to 18.08.2016** from NIB Website www.nib.gov.in or Central Procurement Portal of Govt. of India. However tender fee must be submitted along with the tender document down loaded from website.

Sealed tender should be dropped in tender box at NIB, Noida on or before the closing date, i. e. **19.08.2016** up to **3:00 P. M.** and techno- commercial bid shall be opened on the same day at **4:00 P.M.** in presence of the representatives of the bidders, who are present during opening of the tenders. Late tenders will not be received and treated as rejected.

(Dr. Reba Chhabra)
Dy. Director (Admin.) i/c

National Institute of Biologicals (NIB)



NATIONAL INSTITUTE OF BIOLOGICALS
Plot No.A-32, Sector-62(Institutional Area), NOIDA-201 307(U.P)
Tel: 0120-2400022, 2400072, Fax: 0120-2400074, 2403014
E-mail: info@nib.gov.in Website: www.nib.gov.in

Tender No. 08/2015-2016/Engg. (Civil)

Invitation to Tenders for “Setting-up IT Cell in the Library Building at Ground Floor, opposite to proposed Class Rooms” in NIB Noida”.

Introduction:

“National Institute of Biologicals (NIB) is an autonomous institution under the Ministry of Health & Family Welfare, Government of India, established on 27th January, 1992 and is to be the Central Drugs Laboratory for quality control of all indigenously produced and imported biological products. Presently, five laboratories of the Institute are notified as Central Drugs Laboratory under provision of Drugs & Cosmetics Act and Rules. Institute plays a vital role in collaboration with CDSCO to strengthen the regulation of biologicals in India by averting the Not of Standard Quality Biologicals reaching the consumer, thereby promoting and protecting public health.”

1. Scope of Work:

The contractor has to chase the floors and walls to a minimum width and depth of 75 mm for laying of conduits/ raceways at ground floor of NIB Library Building. The damaged pieces of kota stone shall be repaired with kota stone strips of 6” width and joints will be finished by using white cement mixed with colouring pigment.

Gypsum board false ceiling if damaged for laying conduits etc. is to be cut & removed in regular shape and size. Repair of false ceiling is to be done by fixing new board. Necessary cut-out for light fitting, AC grill etc. will be made in the false ceiling. The repaired portion of the false ceiling will be finished with paint matching with the surrounding areas. Wall will be painted with plastic enamel paint. The work site will be cleaned off any debris/ material etc. and the debris, malwa shall be disposed of outside NIB Campus, at municipal designated dump yard.

The contractor are required to execute electrical works as per BOQ mentioned in tender document.

2. Eligibility Criteria:

- 2.1. Eligibility will be based on meeting the following minimum criteria regarding the Applicant's work experience, personnel and financial position, as demonstrated by the

National Institute of Biologicals (NIB)

Applicant's responses in the tender. The agency should be in the construction business for minimum three financial years ending March, 2016.

2.2. The Applicant to meet the following minimum criteria for eligibility:

(a) Average Annual financial turnover for related works during the last three financial years, ending 31st March, 2016 should be at least **Rs. 5 lakh**.

(b) Experience of having successfully completed similar works during the last seven years ending 30th June, 2016 should be either of the following.

a) Three similar completed works each costing not less than the amount equal to **Rs. 0.8 lakh each**.

Or

b) Two similar completed works each costing not less than the amount equal to **Rs. 1.20 lakh each**.

Or

c) One similar completed work costing not less than the amount equal to **Rs. 1.6 lakh**.

2.3. **Definition of Similar Work: Experience of carrying out Civil, and Electrical works in any Govt. office or large private sector company.**

3. **Earnest Money Deposit (EMD):**

The Bidder shall furnish EMD of **Rs. 4,000/-** (*Four thousand only*) along with the tender in the shape of demand draft in favour of "**National Institute of Biologicals**" payable at **Noida**. EMD shall be returned to the bidders after award of the work. The tender not accompanied with requisite amount of EMD shall be rejected. No interest will be paid on EMD.

4. **Site Visit:**

4.1 The bidder is advised to acquaint himself with the job work, visit the site & examine site conditions, climatic conditions, labour, power, material availability, transport and communication facilities, environmental regulations, laws and byelaws of statutory, local bodies and the Govt. of India and collect all information that will be necessary for preparing the bid and entering into a contract.

The cost of visiting the site and collecting information for the purpose of submission of the bid shall be to the bidder's account.

4.2 The bidder and any of his personnel or agents will be granted permission by NIB to enter upon the site for the purpose of such inspection.

National Institute of Biologicals (NIB)

5. **Submission of Tender:**

The contractor shall submit the tender in the sealed envelope in the following manner.

Envelope No. 1 - shall contain:

- EMD, in the form of demand draft for **Rs. 4,000/-** (*Four thousand only*) in favour of **National Institute of Biologicals, Noida**
- Tender fee of Rs. 525/ if tender document downloaded from NIB website etc.
- Similar work experience certificates in support of fulfilling the eligibility criteria, by the bidder.
- Balance sheet of the company for the last three financial years etc. 2014-15, 2015-16 and 2016-17.
- A copy of tender document duly signed and stamped by the bidder as a token of acceptance of terms & conditions and Bill of Quantities (BOQ) of the tender (**Page No. 1 to 19**)

Envelope No. 2 - Shall contain:

- Price-Bid only. Price shall be filled up by the bidder on the Price-Bid format (**Page No. 20 & 24**) enclosed with the tender by NIB. Price on any other format shall be rejected.

Both the sealed envelopes No. 1 & 2 shall be then put in a bigger envelope duly addressed to **“Director, National Institute of Biologicals, A-32, Sector - 62, Noida - 201 309”** and marked on top Tender for **“Setting-up IT Cell in the Library Building at Ground Floor, opposite to proposed Class Rooms”** in NIB Noida.

6. **Evaluation & Award of work:**

- 6.1 The bids will be evaluated as per the Eligibility criteria given at **Clause -2 above**. The bids which are found to be fulfilling the eligibility criteria shall only be considered for opening of Price-Bids. NIB may seek clarifications in the bids from the bidders during the evaluation process. The work will be awarded to the lowest responsive (L-1), evaluated bidder and Work- order will be issued to the firm. NIB may like to visit the similar completed works of the successful bidder before considering their bid/ award of work.
- 6.2 Substantially responsive financial bids will be checked for any arithmetic errors. Arithmetic errors are to be rectified on the basis of the standard procedure as follows:

National Institute of Biologicals (NIB)

a) If there is a difference between the amount of rate in figure and in words of an item, and the total amount is worked out, then the rate which corresponds to the amount worked by the bidder shall be taken as correct.

b) If the bidder has not worked out the amount of an item, or the same does not correspond with the rates written either in figures or in words, then the rate quoted by him in words shall be taken as correct.

c) If the rate quoted by the bidder in figures and in words tallies, but the amount is not worked out correctly, the rate quoted by the contractor shall be taken as correct and not the amount.

7. **Performance Security:**

7.1 Within 7 days of receipt of work order from NIB, the successful firm shall have to furnish the Performance Security equivalent to 10% of the contact value in the form of Bank Guarantee (from any Nationalized/Scheduled Bank) valid for 60 days beyond expiry of the Defect Liability Period in the format as per **Annexure -A** or in the form of Demand Draft/Pay Order in favour of “**National Institute of Biologicals**” payable at “**Noida**”.

7.2 Failure of the contractor to comply with the requirement of contract shall constitute sufficient grounds for the annulment of the award and forfeiture of the EMD, security Deposit in which event NIB may get the work done at the risk & cost of the Contractor.

8. **Contract Agreement:**

NIB will notify the successful bidder that his tender has been accepted and it will send a work order to the bidder describing the works to be carried out and the same shall be returned duly acknowledged affirmatively by the bidder as a token of acceptance and a contract agreement will be signed between both the parties on the agreement form **Annexure-B**. The contractor shall present the agreement on appropriate value of stamp paper for signature of NIB.

9. **Time of Completion:**

The work shall be completed within **2 (Two) months** from the date of issue / receipt of work order.

10. **Liquidated Damages/ Penalty for Delay:**

If the contractor fails to complete the work within the stipulated time or time extended by the Institute (if any), liquidated damages at the rate of 2% per week/part thereof

National Institute of Biologicals (NIB)

delay subject to maximum 10% of the total work value shall be deducted/ recovered from the contractor.

11. Specifications:

The materials proposed and supplied for use in the work shall be of requisite specifications as specified in the tender and also, reputed make in the industry. The agency may be asked to show proof such as bills/challans/Invoices towards purchase of materials from genuine source.

12. Defect Liability Period:

The materials & work of the contractor shall be under *one year's Defect Liability Period (DLP)*. Defect/s noticed during the defect liability period shall be rectified by the contractor without any cost to NIB, failing which the Security Deposit of the Contractor shall be forfeited. The contractor may also be debarred from any future tendering in the Institute.

13. Payment:

Payment will be made after completion of the work & handing over of the works & materials to NIB. The contractor will submit the bill and payment shall be made within 15 (Fifteen) days from receipt of the bill. Applicable taxes i. e. W.C.T. and TDS etc. will be deducted from the amount payable to the contractor. No advance payment shall be made to the contractor.

14. Bill of Quantity:

The quantities of work given in the Bill of Quantities (*BOQ*) are approximate to give an idea of work. Work will be carried out as per the given scope. The quantities may vary on higher or lower side. The contractor will execute the varied quantity of work on the quoted rates.

15. Validity of Bid:

Validity of bid shall be **90** (*Ninety*) days from the last date of submission of the bid.

16. a) Tools & Tackles:

All tools, tackles such as paint brush, ladders, plate forms, spry machine etc. will be arranged by the contractor and their charges will be deemed to be included in the quoted rates, no extra payment shall be made for the same.

National Institute of Biologicals (NIB)

b) Water & Electricity:

Water & Electricity will be provided free of cost by NIB, at one point near the work place from where contractor will make arrangement of pipes, cables, power plugs, sockets etc. to extend the same to the work place.

17. Risks:

Contractor shall be solely responsible for safety of his workers, working at site by taking insurance cover and by following all safety norms in the trade.

All risks of loss or damage to physical property and of personal injury and death which arise during and in consequence of the performance of the Contract other than the excepted risks are the responsibility of the Contractor. Excepted Risks are:

- a. (i) War, hostilities (whether war be declared or not), invasion, act of foreign enemies.
 - (ii) rebellion, revolution, insurrection, or military or usurped power, or civil war,
 - (iii) Ionising radiations, or contamination by radio-activity from any nuclear fuel, or from any nuclear waste from the combustion of nuclear fuel, radioactive toxic explosive, or other hazardous properties of any explosive nuclear assembly or nuclear component thereof.
 - (iv) Pressure waves caused by aircraft or other aerial devices traveling at sonic or supersonic speed.
- b. Loss or damage due to the use or occupation by the Employer of any section or part of the Permanent Works, except as may be provided for in the Contract.

18. Disputes:

If any dispute or difference of any kind, whatsoever, shall arise between NIB and the Contractor, in connection with or arising out of the Contract, or the execution of the works, whether during the progress of the works or after their completion and whether before or after the termination, abandonment or breach of the contract, it shall, be settled under the Indian Arbitration and Conciliation Act, 1996 or any statutory modification or re-enactment thereof and the rules made there under and for the time being in force shall apply to the arbitration proceedings under this clause. Such arbitration shall be settled by Sole arbitrator who shall be appointed by Director, NIB. The arbitration shall take place in Noida/Delhi unless both parties agree otherwise.

19. Particulars of bidders:

The following details of the bidder are necessary for linking on Central Procurement Portal etc. as per Govt. of India orders. The details may be filled carefully.

Detail of Bidder

1.	Name of Company/ firm/ agency with full address	
2.	Name of Contact Person	
3.	Mobile No.	
4.	Land Line Telephone No.	
5.	Email address	

20. Right to accept or reject the Tender:

Director, NIB reserves the right to accept or reject any or all the tenders without assigning any reason thereof.

Stamp of bidder with signature of authorized signatory,

PROFORMA FOR PERFORMANCE BANK GUARANTEE

(On stamp paper of appropriate value from any Nationalized Bank)

To,

M/s National Institute of Biologicals
Plot No. A - 32, Sector - 62,
NOIDA - 201 309.

Dear Sir,

In consideration of *National Institute of Biologicals* (hereinafter called as the Employer which expression shall include his successor and assigns having awarded to (here in after referred to as the said Contractor or Contractor' when expression shall wherever the subject of context so permits include its successors and assigns) a contract No. In terms inter alia, of the NIB's Letter No. dated. and the General Conditions of Contract and upon the condition of the contractor's furnishing security for the performance of the contractor's obligations and discharge of the contractor's liability under in connection with the said contract up to a sum of Rs..... (Rupees..... only) amounting to 10 % (*Ten*) percent of the total contract value.

1. We (here in after called "The Bank which expression shall include its successors and assigns) hereby jointly and severally undertake to guarantee the payment to The Employer in rupees forthwith on demand in writing and without protest of demur or any and all moneys anywise payable by the contractor to The Employer under in respect of or in connection with the side contract inclusive of all The Employer's losses and damages and costs, (inclusive between attorney and client) charges and expenses and other moneys anywise payable in respect of the above to this guarantee up to an aggregate limit of Rs./- (Rupees.....only).
2. We Bank further agree that The employer shall be sole judge of and as to whether the said contractor has committed any breach or breaches of any of the terms and conditions of the said contract and the extent of loss, damage, cost, charges and expenses caused to or suffered by or that may be caused to or suffered by The Employer on account thereof and the decisions of The Employer that the said Contractor has committed such breach or breaches and as to the amount or amounts of loss, damage, costs, charges and expenses caused to or suffered by The Employer from time to time shall be final and binding on us.

National Institute of Biologicals (NIB)

- 3. The Employer shall be at liberty without reference to the bank and without affecting the full liability of the bank hereunder to take any other security in respect of the Contractor's obligations and liabilities hereunder or to vary the contract or the work to be done thereunder vis-à-vis the Contractor or to grant time or indulgence to the Contractor or to reduce or to increase or otherwise vary the prices of the total contract value or to release or to forbear from enforcement of all or any of the security and/ or any other security (ies) now or hereafter held by the Employer and no such dealing (s) reduction (s) increase (s) or other indulgence (s) or arrangements with the Contractor or release or forbearance whatsoever shall absolve the Bank of the fail liability to The Employer hereunder or prejudice the rights of The Employer against the bank.

- 4. This guarantee shall not be determined or affected by the liquidation or winding up, dissolution, or change of constitution or insolvency of the Contractor but shall in all respect and for all purposes be binding and operative until payment of all monies payable to The Employer in terms thereof.

- 5. The bank hereby waives all rights at any time inconsistent with the terms of this guarantee and the obligations of the bank in terms hereof shall not be anywise affected or suspended by reason of any dispute or dispute having been raised by the Contractor stopping or preventing or purporting to stop or prevent any payment by the bank to The Employer in terms hereof.

- 6. The amount stated in any notice of demand addressed by the Employer to the bank as liable to be paid to the Employer by the Contractor or as suffered or incurred by The Employer on account of any losses or damages of cost, costs, charges and / or expenses shall be conclusive evidence of the amount so liable to be paid to The Employer of suffered or incurred by The Employer as the case may be and shall be payable by the bank to The Employer in terms hereof.

- 7. This guarantee shall be a continuing guarantee and shall remain valid and irrevocable for all claims of the Employer and liabilities of the contractor arising up to and until midnight of.....

- 8. This guarantee shall be addition to any other guarantee or security whatsoever that The Employer may now or at any time anywise may have in relation to the contractor's obligations/ or liabilities under and/ or in connection with the said contract, and The Employer shall have full authority to have recourse to or enforce this security in preference to any other guarantee or security which The Employer may have or obtain and no forbearance on the part of The Employer in enforcing or requiring enforcement of any other security shall have the effect or releasing the Bank from its full liability hereunder.

9. It shall not be necessary for the Employer to proceed against the said Contractor before proceeding against the Bank and the Guarantee herein contained shall be enforceable against the bank notwithstanding that any security which the Employer may have obtained or obtain from the contractor shall at the time when proceedings are taken against the said bank hereunder be outstanding or unrealized.
10. We the said Bank undertake not to revoke this guarantee during its currency except with the consent of the Employer in writing and agree that any change in the constitution of the said contractor or the said Bank shall not discharge our liability hereunder.
11. We.the said Bank further that we shall pay forthwith the amount stated in the notice of demand notwithstanding any dispute/ difference pending between the parties before the arbitrator and/ or that any dispute is being referred to arbitration.
12. Notwithstanding anything contained herein above, our liability under this guarantee shall be restricted to Rs...../- (Rupeesonly) and this guarantee shall remain in force till and unless a claim is made on us within 3 (*Three*) months from that date, that is before all the claims under this guarantee shall be forfeited and we shall be relived of and discharged from our liabilities thereunder.

Datedday of2016.

For and on behalf of Bank.

Issued
Under
Seal

**FORM OF AGREEMENT
(On appropriate value stamp paper)**

AGREEMENT

This agreement made the day of two thousand sixteen between the *National Institute of Biologicals, Plot No. A-32, Sector-62, NOIDA*, (hereinafter called "NIB") of the one part, which expression shall include his successors and assigns and M/s

..... (*hereinafter called "The contractor"*) which expression shall include his heirs, executors, administrators and assigns of the other part.

Whereas NIB is desirous that certain works should be executed by the Contractor, viz for National Institute of Biologicals at NOIDA - 201 309 (U. P) ("the works") and has accepted a Bid of the Contractor for the execution and completion of the works and the remedying of any defects therein.

Now this Agreement witnesses as follows:

1. In this Agreement words and expressions shall have the same meaning as are respectively assigned to them in the Conditions of Contract herein after referred to.
2. The following documents shall be deemed to from and be read and construed as part of this Agreement, viz:
 - a- Tender No. dated:
 - b- Letter No. to M/s
 - c- NIB Work Order letter No. dated:
3. In consideration of the payment to be made by the NIB to the contractor as hereinafter mentioned, the Contractor hereby covenants with NIB to execute and complete the works and remedy any defects therein in conformity in all respect with the provisions of this agreement.

National Institute of Biologicals (NIB)

4. The National Institute of Biologicals hereby covenants to pay the Contractor in consideration of the execution and completion of the works and the remedying of defects therein the Contract Price or such other sum as may become payable at the times and in the manner prescribed by this agreement.

In Witness whereof the parties hereto have this Agreement to be executed the day and year first before written.

Signed, Sealed and Delivered by the Said _____

Binding signature for and on behalf of
National Institute of Biologicals,
A-32, Sector -62, NOIDA.

Binding Signature of Contractor _____

In the presence of

Witness (1):

Witness (2):



NATIONAL INSTITUTE OF BIOLOGICALS
Plot No.A-32, Sector-62(Institutional Area), NOIDA-201 307(U.P)
Tel: 0120-2400022, 2400072, Fax: 0120-2400074, 2403014
E-mail: info@nib.gov.in Website: www.nib.gov.in

BILL OF QUANTITY (BOQ)

Tender No. 08/2015-2016/Engg. (Civil)

Name of work: Tender for "Setting-up IT Cell in the Library Building at Ground Floor, opposite to proposed Class Rooms" - in NIB Noida.

Srl. No.	Description of Item	Unit	Quantity
A.	<u>Civil Works:</u>		
1.	Disposal of building rubbish/malba/ similar unserviceable, dismantled or waste material by mechanical means, including loading, transporting, unloading to approved municipal dumping grounds beyond 50m initial lead, for all leads including all lifts involved.	cum	01
2.	Cutting/chasing of wall and floor (including stone flooring) to a maximum width and depth of 75mm by manual/mechanical means, for laying of conduits/raceways etc. and subsequent repair to give neat levelled surface using by laying PCC of same grade of existing concrete etc. all complete.	rmt	40
3.	Re-laying of cut portions of Kota stone flooring-strips up to 6" width using new polished pieces of kota stone and laying them in true level with existing flooring and finishing the joints using white cement mixed with same color pigment to give a neat and clean finish and subsequent polishing to give a uniform look , etc all complete.	rmt	40
4.	Repairing of damaged gypsum board false ceiling in patches using 12.5mm thick tapered edge gypsum plain board conforming to IS: 2095-Part-1, including removal by mechanical/ manual means (using cutter etc.), without damaging the existing frame work, putting up new gypsum board using standard approved screws/ fixing details etc. applying standard recommended adhesive/ tape to hide joints, applying putty etc. and subsequently applying priming coat using standard approved base paint, etc. all complete.	Sq.mt.	30
5.	Wall Painting With plastic emulsion paint of approved brand and manufacture to give an even shade - one or more coats on old work.	sq.mt.	35

National Institute of Biologicals (NIB)

B.	<u>Electrical Works:</u>		
1.	Providing and installation of Wiring for LAN and telephone points with PVC insulated PVC sheathed annealed tinned copper conductor CAT-6 wire confirming to ITD-S/SW-113B in 20mm dia 16SWG surface/ concealed conduit up to LAN Switch, including cost of providing saddles etc. as required for surface/flush and the cost of cutting and fixing of telephone cord outlet RJ-45 with GI outlet box along with cover plate complete as required including crimping and jack etc. This shall include installation of wire through the existing false ceiling (cost to be included), and in the concealed conduits in walls (to be paid for separately). This shall also include the repair work/ making good any damage / breakage done to the walls/ ceiling or any other route, in the existing specifications so as to give a complete and neat look. Above including the cost of cutting and fixing of telephone cord outlet RJ-45 with GI outlet box along with cover plate complete as required including crimping and jack etc.	meter	600
2.	Providing and installation of 38mm diameter fire proof PVC conduits, bends, T's etc. (Setia/ equilivalent brand) concealed in walls and ceiling. The above shall also include chasing of wall placing and fixing of conduits with suitable brackets/supports and subsequent repairs in plaster to give a neat finish all complete. This shall also include the repair work/ making good any damage / breakage done to the walls / ceiling or any other route, to be finished in the existing specifications so as to give a complete and neat look.	meter	200
3.	Providing and installation of multi strand copper Wiring of required cores(Anchor or equivalent make) from existing DB to the marked area in drawing, through wall (concealed in wall using conduits 25 mm diameter or higher dia. as required) including chasing using electric cutter and subsequent filling and repairing using 1:6 (1 cement , 6 fine sand) plaster to give a neat finish, and finishing in matching paint on top and through the existing metal false ceiling/ gypsum false ceiling, by carefully removing the existing panels/ making holes for passage, laying of conduits, placing the wires in conduits (flexible/ otherwise), securely fastened to wall/ ceiling using suitable brackets/ ties etc. and subsequent re-fixing of ceiling panel/ repairing the gypsum ceiling with existing specifications to return the ceiling to its original position all complete. Long wires to be left for incorporation into the modular work stations. Any repairs resulting out of the above shall be included in this item. Following cores of wires to be provided.		
	4 sq.mm. core (L & N)	meter	1500
	2.5 mm.sq. (E)	meter	600

4.	Providing and installation at positions as per drawing modular switches, sockets of (North West make) including switch box cover plate, chasing of walls and subsequent repair of wall for installation of switch boards for following quantity(note --in case of modular work stations , long wires shall be left to embed in provided raceway of work station later on and switches and sockets as per drawing to be fixed after supply of work stations) -		
	15 (& 5) Amp switch with socket (raw power)	No.'s	11
	15 (& 5) Amp switch with socket (UPS power)	No.'s	22
	Data (LAN) outlet point	No.'s	11
	Telephone outlet point	No.'s	11
5.	Providing and installation of LED down lighter 15watt, Phillips make including choke etc. all complete. This including extension of wires from existing point in ceiling and cutting of existing ceiling as per the new light all complete.	each	11
6.	Providing and installation of MCB 20Amp rating (Havells or equivalent) including fixing in existing box or otherwise including all mounting gear and also including making all connections using recommended wiring etc. all complete.	each	22
7.	Providing and installation of 24 port Switch (cisco make) for LAN extension, including fixing and integration with the existing system/ server etc. all complete.	each	1
8.	Providing and installation of wall mounted switch rack of approved make.	each	1
9.	Providing and installation of MCB box 4Way three phase, along with RCCB 40A	each	1

Stamp of bidder with signature of authorized signatory,

National Institute of Biologicals (NIB)

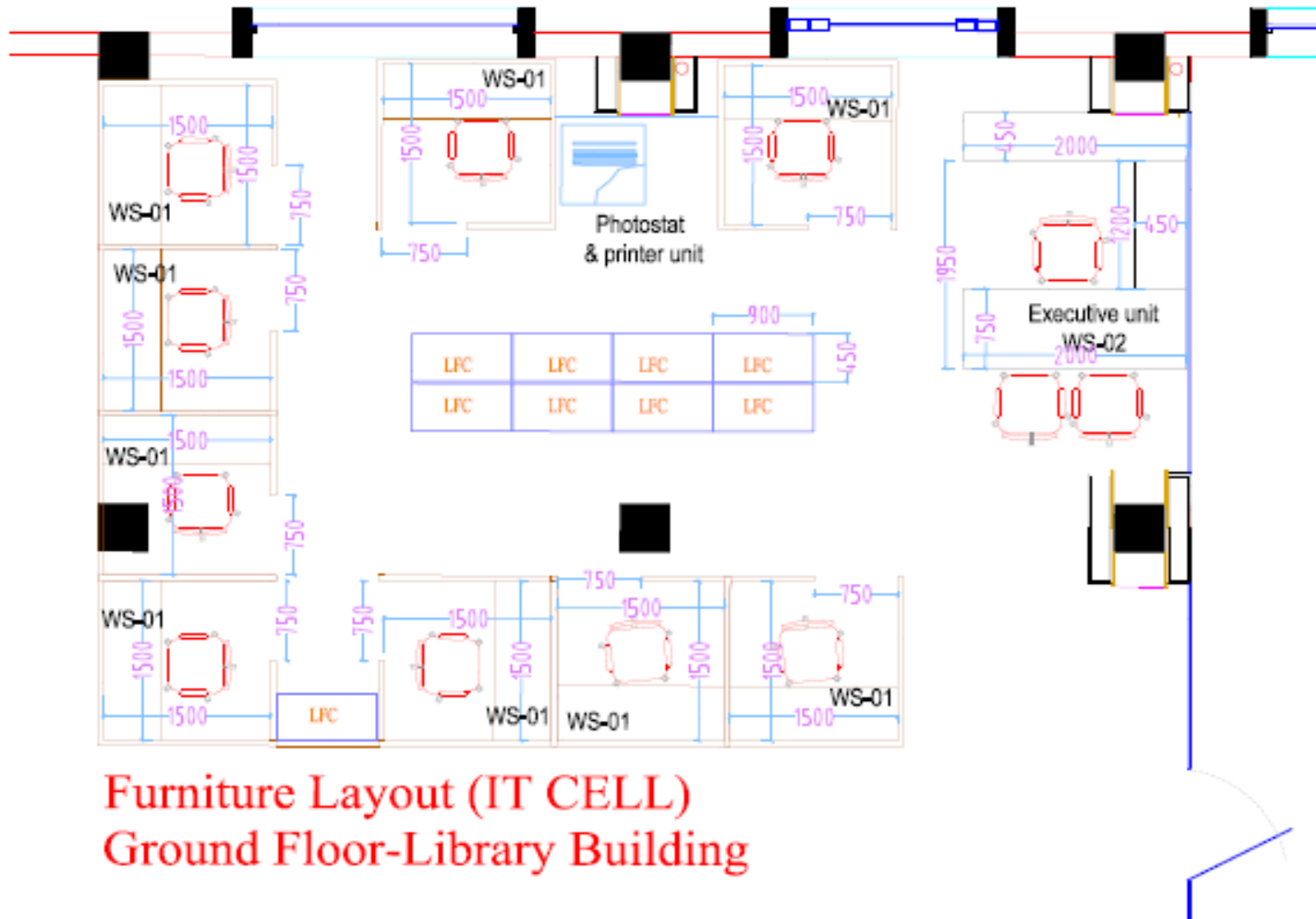

**Furniture Layout (IT CELL)
Ground Floor-Library Building**

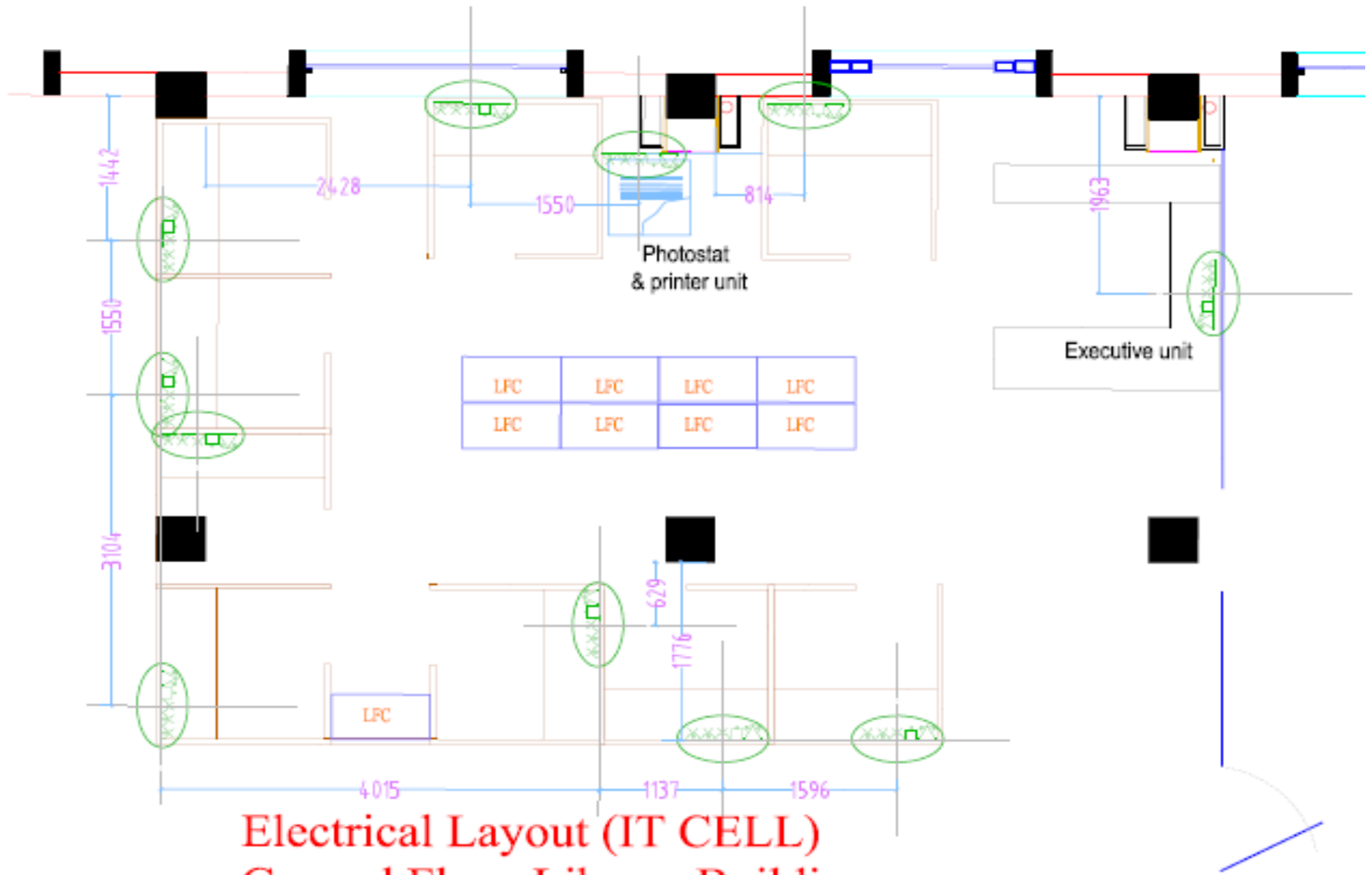

Electrical Layout (IT CELL) Ground Floor-Library Building



NATIONAL INSTITUTE OF BIOLOGICALS
Plot No.A-32, Sector-62(Institutional Area), NOIDA-201 307(U.P)
Tel: 0120-2400022, 2400072, Fax: 0120-2400074, 2403014
E-mail: info@nib.gov.in Website: www.nib.gov.in

PRICE-BID

Tender No. 08/2015-2016/Engg. (Civil)

Name of work: Tender for “Setting-up IT Cell in the Library Building at Ground Floor, opposite to proposed Class Rooms” - in NIB Campus Noida.

Srl. No.	Description of Item	Unit	Qty.	Rate (in figure & words) (Rs.)	Amount (in figure & words) (Rs.)
A.	<u>Civil Works:</u>				
1.	Disposal of building rubbish/malba/ similar unserviceable, dismantled or waste material by mechanical means, including loading, transporting, unloading to approved municipal dumping grounds beyond 50m initial lead, for all leads including all lifts involved.	cum	01		
2.	Cutting/chasing of wall and floor (including stone flooring) to a maximum width and depth of 75mm by manual/mechanical means, for laying of conduits/raceways etc. and subsequent repair to give neat levelled surface using by laying PCC of same grade of existing concrete etc. all complete.	rmt	40		

National Institute of Biologicals (NIB)

3.	Re-laying of cut portions of Kota stone flooring-strips up to 6" width using new polished pieces of kota stone and laying them in true level with existing flooring and finishing the joints using white cement mixed with same color pigment to give a neat and clean finish and subsequent polishing to give a uniform look , etc all complete.	rmt	40		
4.	Repairing of damaged gypsum board false ceiling in patches using 12.5mm thick tapered edge gypsum plain board conforming to IS: 2095-Part-1, including removal by mechanical/ manual means (using cutter etc.), without damaging the existing frame work, putting up new gypsum board using standard approved screws/ fixing details etc. applying standard recommended adhesive/ tape to hide joints, applying putty etc. and subsequently applying priming coat using standard approved base paint, etc. all complete.	Sq.mt.	30		
5.	Wall/ceiling Painting With plastic emulsion paint of approved brand and manufacture to give an even shade - one or more coats on old work.	sq.mt.	35		
<u>TOTAL (A) Civil Works</u>					
<u>B.</u>	<u>ELECTRICAL & IT WORK:</u>				
1.	Providing and installation of Wiring for LAN and telephone points with PVC insulated PVC sheathed annealed tinned copper conductor CAT-6 wire confirming to ITD-S/SW-113B in 20mm dia 16SWG surface/concealed conduit up to LAN Switch, including cost of providing saddles etc. as required for surface/flush and the cost of cutting and fixing of telephone cord outlet RJ-45 with GI outlet box along with cover plate complete as required including crimping and jack etc. This shall include	meter	600		

	installation of wire through the existing false ceiling (cost to be included), and in the concealed conduits in walls (to be paid for separately). This shall also include the repair work/ making good any damage / breakage done to the walls/ ceiling or any other route, in the existing specifications so as to give a complete and neat look. Above including the cost of cutting and fixing of telephone cord outlet RJ-45 with GI outlet box along with cover plate complete as required including crimping and jack etc.				
2.	Providing and installation of 38mm diameter fire proof PVC conduits, bends, T's etc. (Setia/ equivalent brand) concealed in walls and ceiling. The above shall also include chasing of wall placing and fixing of conduits with suitable brackets/supports and subsequent repairs in plaster to give a neat finish all complete. This shall also include the repair work/ making good any damage / breakage done to the walls / ceiling or any other route, to be finished in the existing specifications so as to give a complete and neat look.	meter	200		
3.	Providing and installation of multi strand copper Wiring of required cores(Anchor or equivalent make) from existing DB to the marked area in drawing, through wall (concealed in wall using conduits 25 mm diameter or higher dia. as required) including chasing using electric cutter and subsequent filling and repairing using 1:6 (1 cement , 6 fine sand) plaster to give a neat finish, and finishing in matching paint on top and through the existing metal false ceiling/ gypsum false ceiling, by carefully removing the existing panels/ making holes for passage, laying of conduits, placing the wires in conduits (flexible/ otherwise), securely fastened to wall/ ceiling using suitable brackets/ ties etc. and subsequent re-fixing of ceiling				

	panel/ repairing the gypsum ceiling with existing specifications to return the ceiling to its original position all complete. Long wires to be left for incorporation into the modular work stations. Any repairs resulting out of the above shall be included in this item. Following cores of wires to be provided.				
	4 sq.mm. core (L & N)	meter	1500		
	2.5 mm.sq. (E)	meter	600		
4.	Providing and installation at positions as per drawing modular switches, sockets of (North West make) including switch box cover plate, chasing of walls and subsequent repair of wall for installation of switch boards for following quantity(note --in case of modular work stations , long wires shall be left to embed in provided raceway of work station later on and switches and sockets as per drawing to be fixed after supply of work stations)				
	15 (& 5) Amp switch with socket (raw power)	No.'s	11		
	15 (& 5) Amp switch with socket (UPS power)	No.'s	22		
	Data (LAN) outlet point	No.'s	11		
	Telephone outlet point	No.'s	11		
5.	Providing and installation of LED down lighter 15watt, Phillips make including choke etc. all complete. This including extension of wires from existing point in ceiling and cutting of existing ceiling as per the new light all complete.	each	11		
6.	Providing and installation of MCB 20Amp rating (Havells or equivalent) including fixing in existing box or otherwise	each	22		

	including all mounting gear and also including making all connections using recommended wiring etc. all complete.				
7.	Providing and installation of 24 port Switch (cisco make) for LAN extension, including fixing and integration with the existing system/ server etc. all complete.	each	1		
8.	Providing and installation of wall mounted switch rack of approved make.	each	1		
9.	Providing and installation of MCB box 4Way three phase, along with RCCB 40A	each	1		
	Total (B) Electrical & IT Works				
	Total = (A) Civil Works + (B) Electrical & IT Works				
	Service tax @..... if any				
	Total amount with tax				

Amount (in words):

.....

- i) *Validity of Bid shall be 90 days from the last date of submission of the bid.*
- ii) *Taxes/ duties not specified in Price-Bid will be treated as inclusive.*

Stamp of bidder with signature of authorized signatory,

National Institute of Biologicals (NIB)